

CARD LASER  
ISSUANCE  
SYSTEM

**MATICA**

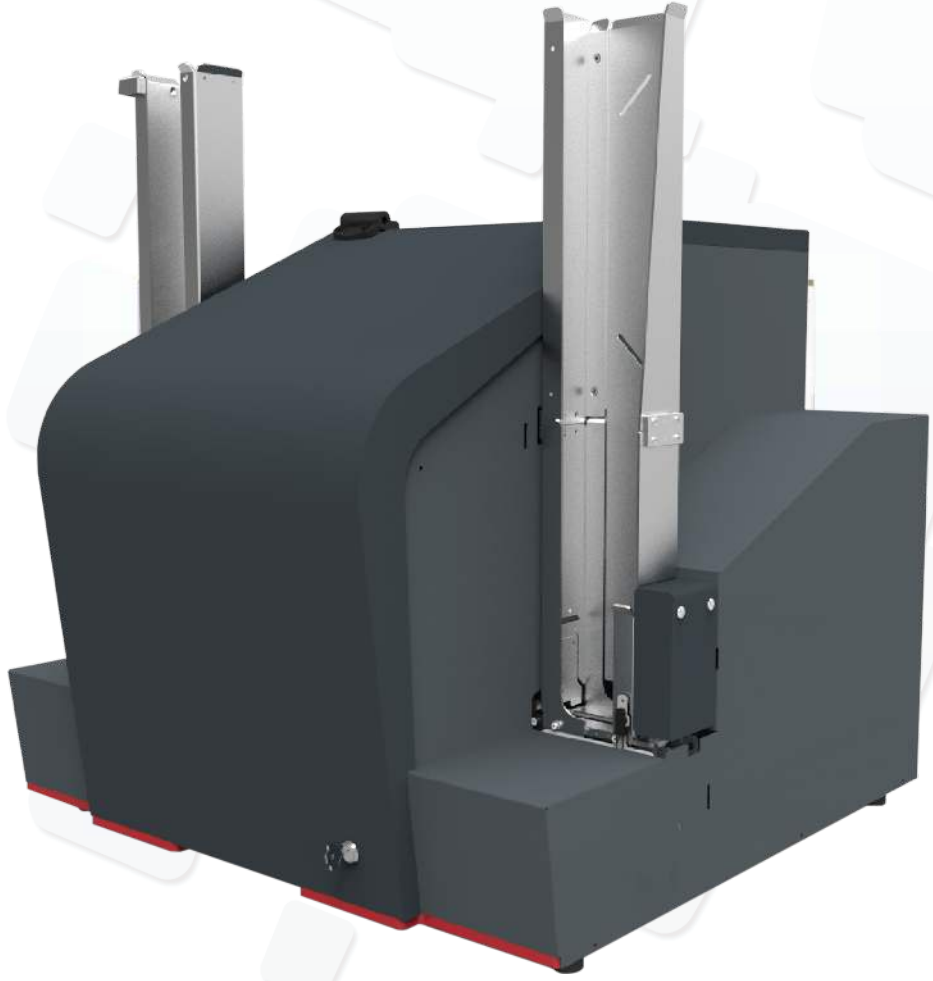

S4200LX





# S4200LX

## CARD LASER ISSUANCE SYSTEM

The S4200LX is the best-in-class engraving solution for decentralized on-site ID card issuance. The system offers a proven, reliable structure for volume issuance already deployed in the field. Its sweet spot lies in highly secure Polycarbonate ID card personalization with embedded security features such as micro-text, tilted image/text and transparent-opaque elements. The state-of-the-art laser source and the dual module architecture fulfils the most demanding requirements in terms of flexibility, performances, quality of engraving and handling of delicate or specialty cards.

### SPECIAL APPLICATIONS

The S4200LX is designed to meet the growing demand in the low volume issuance of very specific documents such as:

- National identification cards
- Driving licenses
- Vehicle registration documents
- Resident permits
- Gun / firearms licenses

All documents require certain levels of security to be embedded in the document to reduce the risk of counterfeiting and to provide options for overt and forensic detection.

### DIVERSIFIED SOLUTION

The range of Matica's laser card issuance extends from instant issuance to low, mid and high-volume solutions. All of them are specifically calibrated and tuned for the application they are designed to do, and no matter what solution is used the result is an excellently produced document with the same high finish. For our customers involved in complex projects, this offers a unique proposition that combines instant and central issuance as well as a distribution component as and when it is required.

### MATICARDPRO SOFTWARE

MaticardPro software is Matica's standard production software and features in numerous products, markets and applications. Typically, it needs some interface with pre-existing MaticardPro software in order to issue secure documents, but it can also interface with third party software with a quick and easy setup alongside with its multiple platform database connection options.

## TECHNICAL SPECIFICATIONS

### Productivity

- Up to 250 cards per hour (cph)
- Recommended operating: up to 1,000 cards over 24 hours

### Base Machine

- 600-card feeder + 600 card stacker with reject card tray
- LX laser station with Tripod™ card transport for dual-side marking
- Integrated filtering, MaticardPro production SW License

### Options

- Single Contact, Contactless or Dual interface Smart Card encoding station, External filtering
- CLI and/or MLI marking
- Vision option for Positioning and/or Data Validation

### Fonts

- Vector laser and true type

### Laser Station

- 10W fiber laser
- Protected marking chamber with inspection window

### Software

- Laser marking software for laser layout creation
- MaticardPro card production software with third party GUI integration option
- Smartcard SDK
- Supported OS: Win 7, Win 8 and Win 10.

### Communication Interface

- USB 2.0 - Ethernet

### Dimensions & Weight

- L x W x H: 630mm x 690mm x 700mm (25" x 27" x 28")
- Approx. 45kg (depending on config.)

### Electrical Requirements

- Auto-switching internal power supply: Input 100-240 volts AC 50-60Hz – 450W (depending on config.)



Matica  
sales@maticacorp.com

maticacorp.com

Data subject to change without notice. All trademarks stated are the property of their respective owners. S4200LX\_PD\_2021\_04\_ENG\_A4